

150W Ku-Band Compact Outdoor 1:1 Redundant System

DESCRIPTION

Teledyne Paradise Datacom's **Outdoor** series of redundant amplifier systems provide the highest degree of earth station redundancy and reliability. Based on Teledyne Paradise Datacom's family of rugged and robust SSPAs, these systems provide the highest MTBFs possible.

These systems can be configured in either 1:1 or 1:2 redundant configurations using any of the Teledyne Paradise Datacom family of Outdoor SSPAs. The RCP2-1100/1200 Redundant Controller provides an extremely user-friendly interface for complete monitor and control of the high power amplifiers in either 1:1 or 1:2 configurations.

The RCP front panel mimic display shows the on-line amplifiers and the current switch positions. Dedicated fault lights provide easy indication of system status. All RCP2-1X00 monitor and control is available locally, at the front panel LCD display, as well as remotely by the RS-232 or RS-485 interface ports.

FEATURES

- System Output Power to:
1000W L-Band;
1000W S-Band;
1000W C-Band;
800W X-Band;
600W Ku-Band
- Universal Input, Power Factor Corrected Power Supply
- Output Power Monitoring
- Separate 1RU Redundant Controller or Controller-less configurations

OPTIONS

- System Output Power Monitor
- Reflected Power Alarm
- W/G Arc Protection Kit
- L-Band Input Operation
- Cold Standby Operation
- Custom Configurations



High Power Outdoor Output Power Ranges

Band	GaAs (W)	GaN (W)
L-Band	N/A	600 - 1kW
S-Band	N/A	600 - 1kW
C-Band	400 - 600	800 - 1kW
X-Band	N/A	800
Ku-Band	N/A	400 - 600

See document # 214164 for GaAs High Power Outdoor SSPAs, and document # 211669 for GaN High Power Outdoor SSPAs

Compact Outdoor Output Power Ranges

Band	GaAs (W)	GaN (W)
L-Band	N/A	100 - 500
S-Band	N/A	100 - 500
C-Band	75 - 300	300 - 500
X-Band	200	300 - 400
Ku-Band	100 - 125	200 - 250

See document # 205485 for GaAs Compact Outdoor SSPAs, and document # 209555 for GaN Compact Outdoor SSPAs

System Output Power Capacity

Due to residual losses inherent in redundant system configurations (waveguide bends; switch and coupler losses), reduce the typical output power specification of a single amplifier by approximately 0.2 dB for 1:1 and by 0.4 dB for 1:2 systems.

For example, a single thread 100W Ku-Band Compact Outdoor SSPA has a typical saturated output power of 50.0 dB (100W).

Placing two of the above amplifiers in a 1:1 redundant system configuration would reduce the typical system saturated output by 0.2 dB to 49.8 dB (96W).

Placing three of the above amplifiers in a 1:2 redundant system configuration would reduce the typical system saturated output by 0.4 dB to 49.6 dB (91W).

Actual system losses will vary based on the system options.

General Specifications

PARAMETER	NOTES	LIMITS	UNITS
Gain	minimum	70	dB
Gain Flatness	full band	± 1.0	dB
Gain Slope	full band (Extended C-Band) per 40 MHz (C-, X-, Ku-Bands)	± 1.5	dB
Gain Variation vs. Temperature	per 10 MHz (L-, S-Band)	± 0.3	dB/40 MHz
Gain Stability	-30 °C to +50 °C	± 0.2	dB/10 MHz
Gain Adjustment	at constant temperature	± 1.0	dB
	0.1 dB resolution	20	dB
Intermodulation Distortion	3 dB back off relative to P _{1dB}	-25	dBc
AM/PM Conversion	(@ rated P _{1dB})	3.5	°/dB
	(@P _{1dB} - 3 dB)	1.0	°/dB
Spurious Harmonics	(@ rated P _{1dB})	-65	dBc
	(@ rated P _{1dB} - 3 dB) (C-,X-,Ku-bands)	-50	dBc
	(@ rated P _{1dB} - 3 dB) (L-, S-band)	-30	dBc
Input/Output VSWR		1.50:1	
	Output VSWR: Ku-Band with bulkhead filter	1.40:1	
Noise Figure	at maximum gain (C-,X-,Ku-bands)	10	dB
	at maximum gain (L-, S-Band)	8	dB
Group Delay (per 40 MHz segment)	Linear	0.01	ns/MHz
	Parabolic	0.003	ns/MHz ²
	Ripple	1.0	ns p-p
Transmit Band Noise Output Power Density	TX Band	-75	dBW/4 KHz
	RX Band (C- or Ku-bands)	-150	dBW/4 KHz
	RX Band (X-Band)	-100	dBW/4 KHz
	RX Band (L-, S-Band)	See options	
Receive Band Noise Output Power Density	L-, S-Band, with optional filter	-155	dBW/4 KHz
	L-, S-Band, without optional filter	-95	dBW/4 KHz
Residual AM Noise	0 - 10 KHz	-45	dBc
	10 KHz - 500 KHz	-20 (1.25 + log F)	dBc
	500 KHz - 1 MHz	-80	dBc
Phase Noise	Offset frequency from carrier		
	10 Hz	-90	dBc/Hz
	100 Hz	-100	dBc/Hz
	1 KHz	-110	dBc/Hz
	10 KHz	-120	dBc/Hz
	100 KHz	-125	dBc/Hz
	1 MHz	-130	dBc/Hz

Environmental

Operating Temperature	Ambient	-40 to +60	°C
Relative Humidity	condensing	100	%
Cooling System	Integrated	Forced air	

Mechanical

Size, High Power Outdoor, single	width X length X height	16.5 X 27.5 X 9.335	inches
Size, Compact Outdoor, single	width X length X height	419 X 699 X 238	mm
		10.0 X 19.5 X 6.50	inches
		254 X 495 X 165	mm
Weight, High Power Outdoor, single	Base unit (<200W S/C-bands)	100 (45.5)	lbs. (kg)
Weight, Compact Outdoor, single	Base unit (≥200W S/C-bands; ≥100W Ku)	36 (16.4) ± 3%	lbs. (kg)
	Base unit (≥200W X-Band)	44 (20.0) ± 3%	lbs. (kg)
	With Internal zBUC	54.9 (25.0) ± 3%	lbs. (kg)
		+1.7 (0.8)	lbs. (kg)
Finish		Paint	White; powder coat

L-Band Operation

Teledyne Paradise Datacom amplifiers are available with an integrated L-Band Block Up Converter. L-Band units utilize Teledyne Paradise Datacom's proprietary zBUC technology. Adding a zBUC® converter to an SSPA typically increases the gain by 2-4 dB. In addition:

- the zBUC converter can detect and switch to an externally supplied reference.
- an optional internal high stability (10MHz) reference is available.
- the zBUC converter can lock to an externally supplied reference of 10 or 50 MHz.
- the zBUC converter can accept a wide range of external reference power (-10 to +5 dBm)
- the zBUC converter can accept FSK monitor and control signal via the IFL.

Available Frequency Plans

Band	Model Number	IF Input	LO Frequency	RF Output
C	Sub-Band "A"	950 - 1525 MHz	4.900 GHz	5.850 - 6.425 GHz
C	Sub-Band "B"	950 - 1825 MHz	4.900 GHz	5.850 - 6.725 GHz
C	Sub-Band "C"	950 - 1870 MHz	4.800 GHz	5.750 - 6.670 GHz
C	Sub-Band "E"	950 - 1250 MHz	5.475 GHz	6.425 - 6.725 GHz
C	Sub-Band "F"	950 - 1250 MHz	5.775 GHz	6.725 - 7.025 GHz
C	Sub-Band "G"	950 - 1675 MHz	4.800 GHz	5.750 - 6.475 GHz
C	Sub-Band "L"	950 - 1550 MHz	3.450 GHz	4.400 - 5.000 GHz
X	Sub-Band "A"	950 - 1450 MHz	6.950 GHz	7.900 - 8.400 GHz
Ku	Sub-Band "A"	950 - 1450 MHz	13.050 GHz	14.00 - 14.50 GHz
Ku	Sub-Band "B"	950 - 1700 MHz	12.800 GHz	13.75 - 14.50 GHz

Electrical Specifications for Outdoor SSPA with ZBUC converter

PARAMETER	NOTES	LIMITS				UNITS
Gain	Nominal setting	75				dB
Gain Flatness	full band (C-,X-,Ku-bands)	± 2.0				dB
Gain Slope	per 40 MHz (C-,X-,Ku-bands)	± 0.5				dB/40 MHz
Gain Adjusted Range		20				dB
	Typical C-Band Adj. Range	60 - 80				dB
	Typical Ku-Band Adj. Range	57 - 77				dB
Gain Stability	-40 to +60 °C	± 1.5				dB
Phase Noise	Offset frequency from carrier	Absolute max.	C-band (typ.)	X-band (typ.)	Ku-band (typ.)	
	10 Hz	-30	-60	-58	-56	dBc/Hz
	100 Hz	-60	-74	-70	-67	dBc/Hz
	1 KHz	-70	-84	-80	-78	dBc/Hz
	10 KHz	-80	-100	-94	-91	dBc/Hz
	100 KHz	-90	-105	-97	-94	dBc/Hz
	1 MHz	-90	-125	-122	-120	dBc/Hz
Spurious	In-Band Signal Related (C-/Ku-Band) (Extended C-Band)	-50				dBc
	Close to Carrier Spurious (≤ 20 MHz)	-40				dBc
	Local Oscillator	-50				dBc
		-30				dBm
Noise Figure	At Maximum gain	20				dB
Transmit Band Noise Output Power Density	Tx Band at Maximum gain	-65				dBW/4kHz
Input VSWR	L-Band	1.5 : 1				
Internal Reference Option	Reference Accuracy (initial)	± 1 • 10 ⁻⁸				
	Aging per day (after 30 days)	± 1 • 10 ⁻⁹				
	Aging per year (after 30 days)	± 6 • 10 ⁻⁸				
	Reference Stability over Temperature (-40 to +40 °C, ambient)	± 1 • 10 ⁻⁸				

Reference Options in Redundant Systems with L-Band Input

See below for BUC configurations in which the 10 MHz reference can be distributed to units in redundant systems. Converters with internal reference oscillators automatically switch to an externally applied reference.

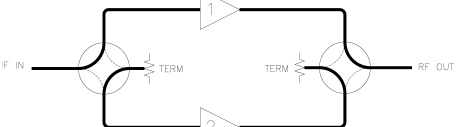
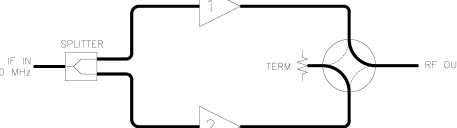
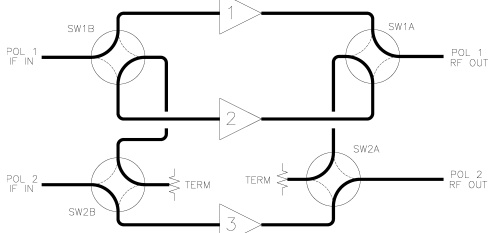
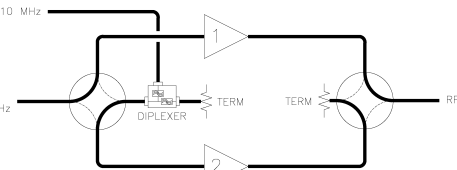
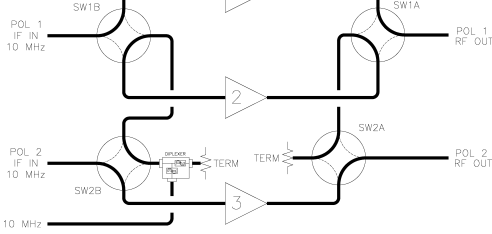
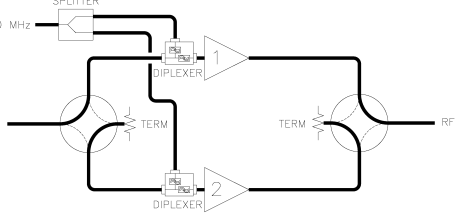
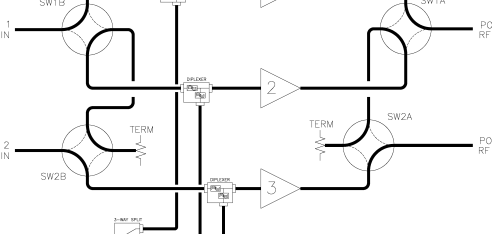
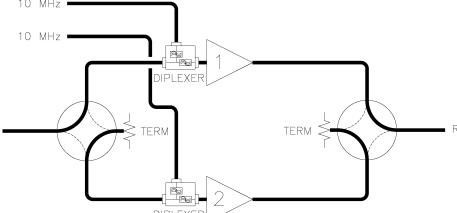
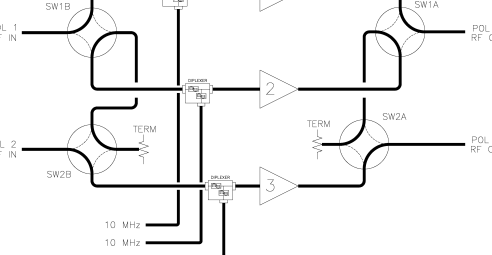
1:1 Redundant Systems	Ref. Option	1:2 Redundant Systems
<p>Internal Reference Standard for BUC option 'M' with input switching</p>  <p>Internal/External Reference Standard for BUC option 'M' or 'P' with input splitting</p> 	<p>Option 1</p>	<p>Internal Reference Standard for BUC option 'M'</p> 
<p>External 10 MHz Diplexed to Standby Unit</p> 	<p>Option 2</p>	<p>External 10 MHz Diplexed to Standby Unit</p> 
<p>Single External 10 MHz Diplexed to Each Unit Standard for BUC option 'P' with input switching</p> 	<p>Option 3</p>	<p>Single External 10 MHz Diplexed to Each Unit Standard for BUC option 'P'</p> 
<p>Separate External 10 MHz Diplexed to Each Unit</p> 	<p>Option 4</p>	<p>Separate External 10 MHz Diplexed to Each Unit</p> 

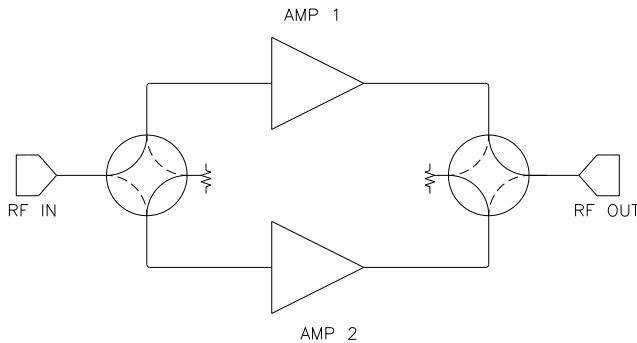

1:1 Redundant HPA System

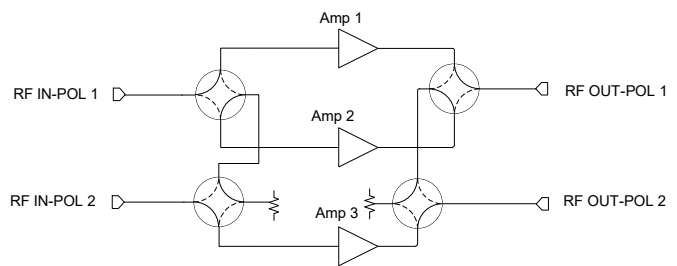

1:2 Redundant HPA System

Teledyne Paradise Datacom's Outdoor Packaged Redundant Systems are designed with built-in redundancy for 1:1 systems. All system-level monitor and control is internal and no separate controller is required, although an optional RCP2-1100 1:1 Redundant System Controller is available. Either Ethernet or RS-485 communications are selectable for user monitor and control. All 1:2 redundant systems require a separate RCP2-1200 Redundant System Controller.

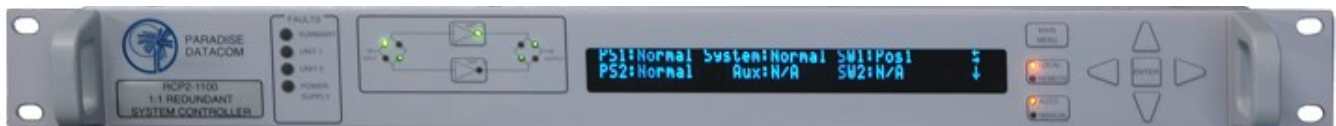

RCP2-1100 1:1 Redundant System Controller

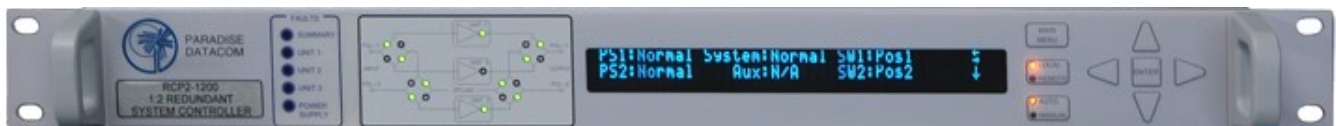

RCP2-1200 1:2 Redundant System Controller

The RCP2-1200 1:2 Redundant System Controller is the heart of the 1:2 redundant system. It provides an extremely user friendly interface for complete monitor and control of the high power amplifiers. The front panel mimic display shows the on-line amplifiers and the current switch positions. Dedicated fault lights are provided for easy indication of system status.

All Redundant System Controller monitor and control is available locally, at the front panel LCD display, as well as remotely by the RS-232, RS-485 or Ethernet interface ports. Audible alarms and a full compliment of parallel I/O signal are available at the rear panel.

Outline Drawing, 1:1 Ku-Band High Power Outdoor SSPA System with RCP2-1100

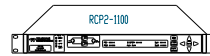
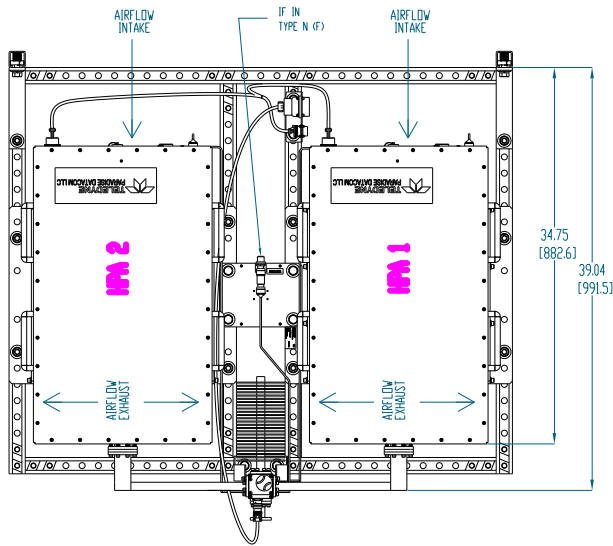

SWITCH CONTROL CABLE

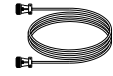

M/C CABLE

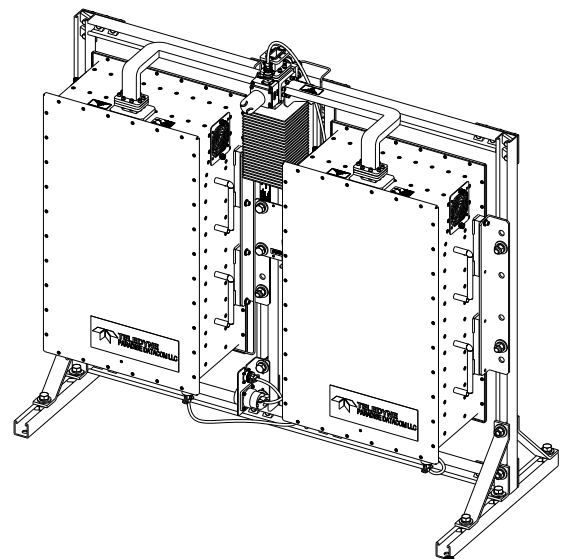
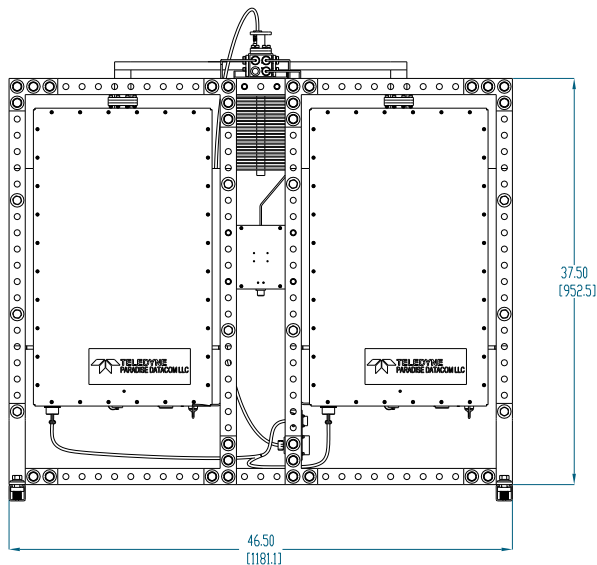
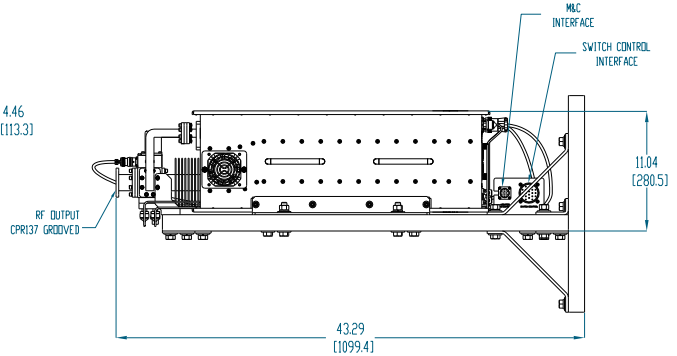
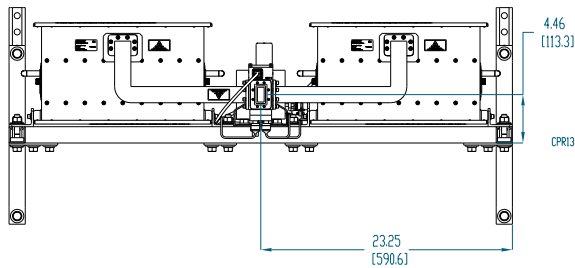

Outline Drawing, 1:2 C-Band Compact Outdoor SSPA System with RCP2-1200

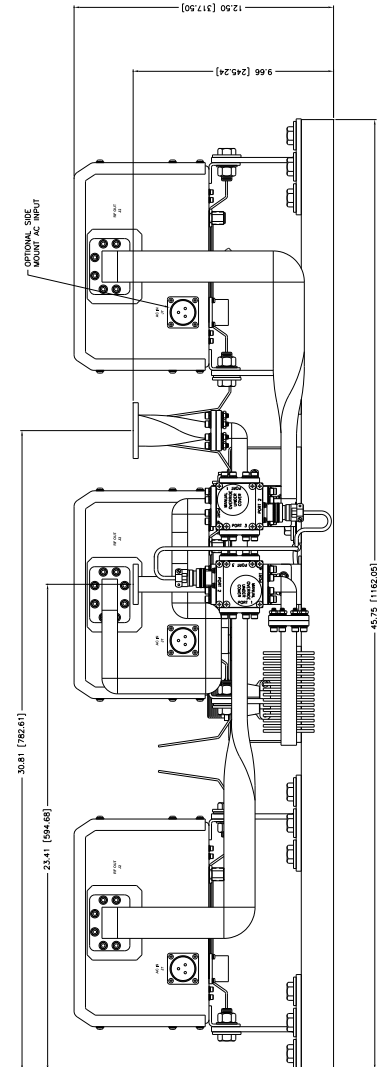
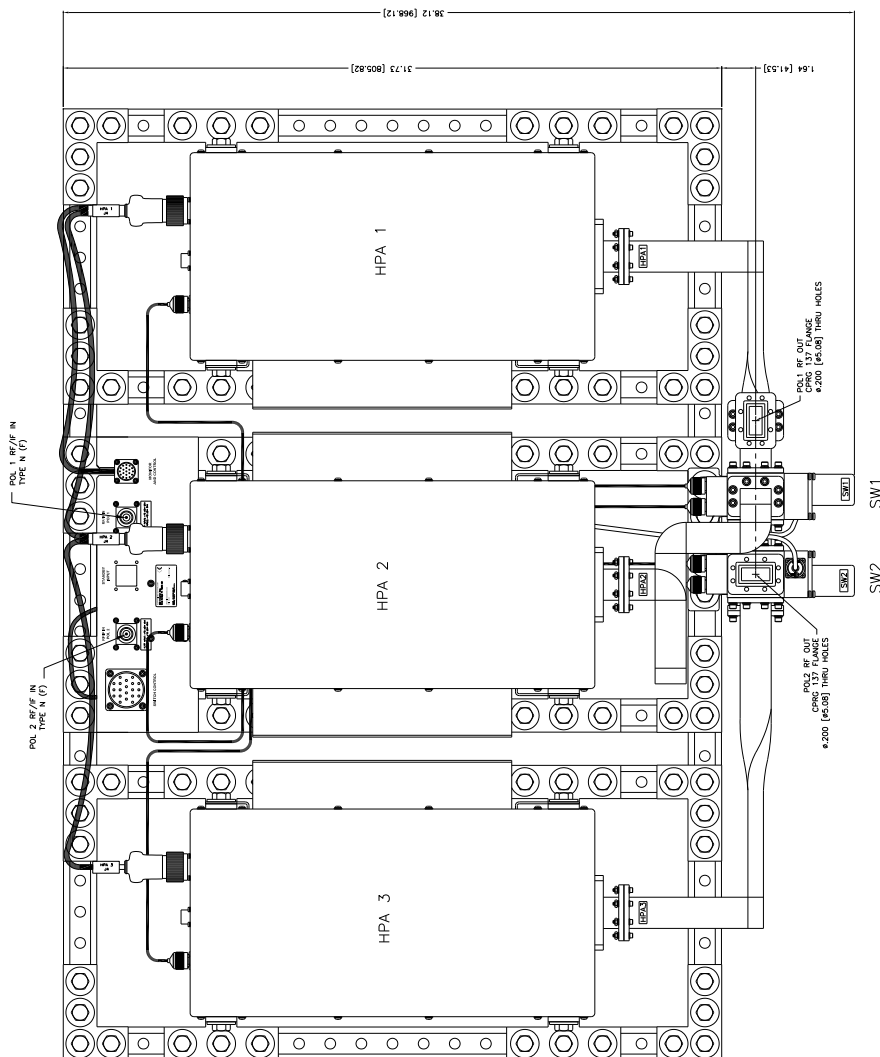
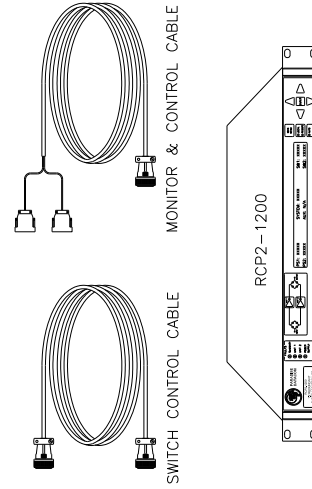
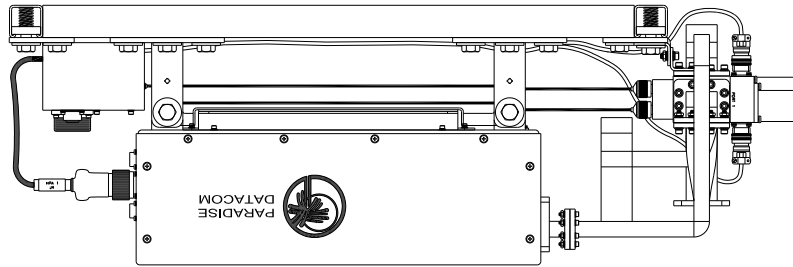

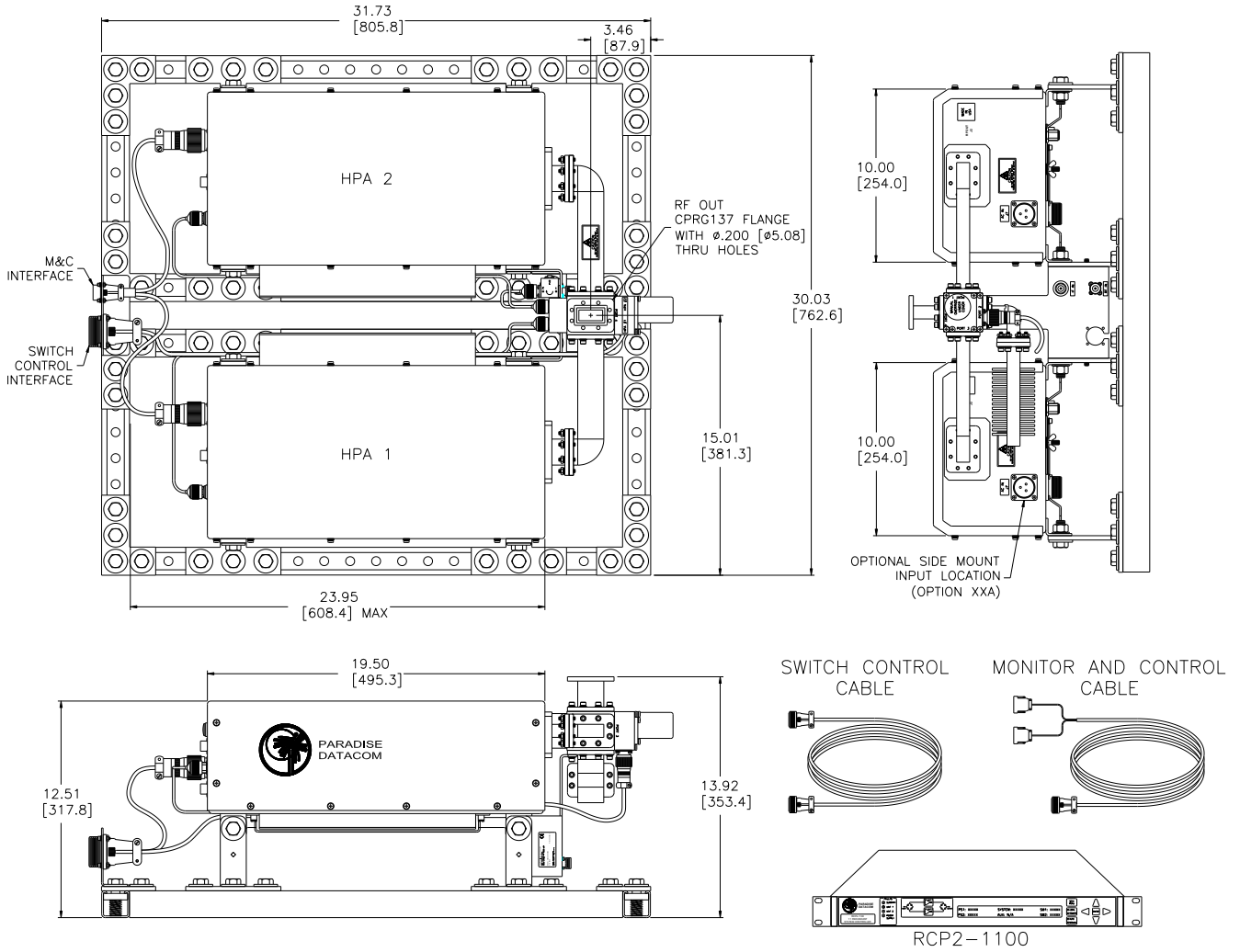

Outline Drawing, 1:1 C-Band Compact Outdoor SSPA System with RCP2-1100

Part Number Configuration Matrix, GaAs High Power Outdoor Systems

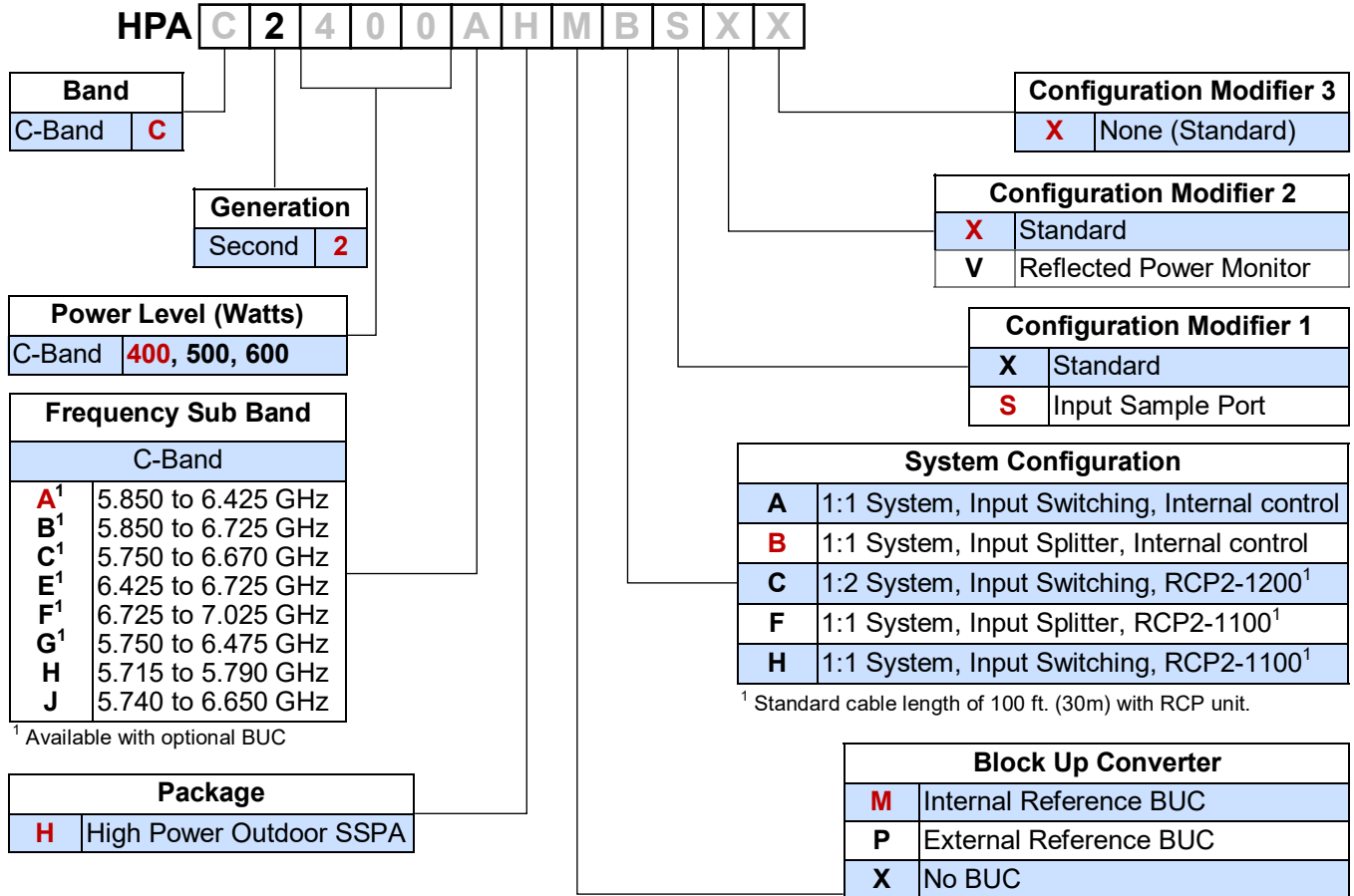

See page 5 for BUC reference configuration options.
Option 1 is standard for all 1:1 and 1:2 systems using BUC option 'M' and for 1:1 systems with input splitting using BUC option 'P'.
Option 3 is standard for all 1:2 systems and 1:1 systems with input switching using BUC option 'P'.

Example — A 1:1 Redundant System with Input Splitting and Internal Redundancy Control, using two (2) 400W GaAs C-Band High Power Outdoor SSPAs with optional input sample ports and optional internal reference block up converters is part number: **HPAC2400AHMBSXX**.

COMMENTS:

Part Number Configuration Matrix, GaN High Power Outdoor Systems

HPA **C 2 8 0 0 A H M B X X X G**

Band	
L-Band	L
S-Band	S
C-Band	C
X-Band	X
Ku-Band	K

Generation	
Second	2

Power Level (Watts)	
L-Band	600, 800, 1000 (10K)
S-Band	600, 800, 1000 (10K)
C-Band	800, 1000 (10K)
X-Band	800
Ku-Band	400, 500, 600

Frequency Sub Band	
L-Band	
A	1.75 to 1.85 GHz
S-Band	
A	2.02 to 2.12 GHz
B	2.20 to 2.30 GHz
G	1.75 to 2.12 GHz
C-Band	
A ¹	5.850 to 6.425 GHz
B ¹	5.850 to 6.725 GHz
C ¹	5.750 to 6.670 GHz
E ¹	6.425 to 6.725 GHz
F ¹	6.725 to 7.025 GHz
H	5.715 to 5.790 GHz
L ¹	4.400 to 5.000 GHz
X-Band	
A ¹	7.90 to 8.40 GHz
F	7.10 to 7.40 GHz
Ku-Band	
A ¹	14.00 to 14.50 GHz
B ¹	13.75 to 14.50 GHz

¹ Available with optional BUC

Example — A 800W GaN C-Band (5.85 to 6.425 GHz) 1:1 Redundant High Power Outdoor SSPA System with input splitting, an internal reference block up converter and internal redundancy control is model number: **HPAC2800AHMBXXXG**.

GaN Device Designator	
G	GaN Technology

Configuration Modifier 3	
X	None (Standard)

Configuration Modifier 2	
X	Standard
R ¹	Receive Band Reject Filter
V	Reflected Power Monitor
Y ¹	R + V (see above)

¹ S-Band and X-Band only

Configuration Modifier 1	
X	Standard
S	Input Sample Port

System Configuration	
A	1:1 System, Input Switching, Internal control
B	1:1 System, Input Splitter, Internal control
C	1:2 System, Input Switching, RCP2-1200 ¹
F	1:1 System, Input Splitter, RCP2-1100 ¹
H	1:1 System, Input Switching, RCP2-1100 ¹

¹ Standard cable length of 100 ft. (30m) with RCP unit.

Block Up Converter	
M	Internal Reference BUC
P	External Reference BUC
X	No BUC

See page 5 for BUC reference configuration options. **Option 1** is standard for all 1:1 and 1:2 systems using BUC option 'M' and for 1:1 systems with input splitting using BUC option 'P'. **Option 3** is standard for all 1:2 systems and 1:1 systems with input switching using BUC option 'P'.

Package	
H	High Power Outdoor SSPA

COMMENTS:

Part Number Configuration Matrix, GaAs Compact Outdoor Systems

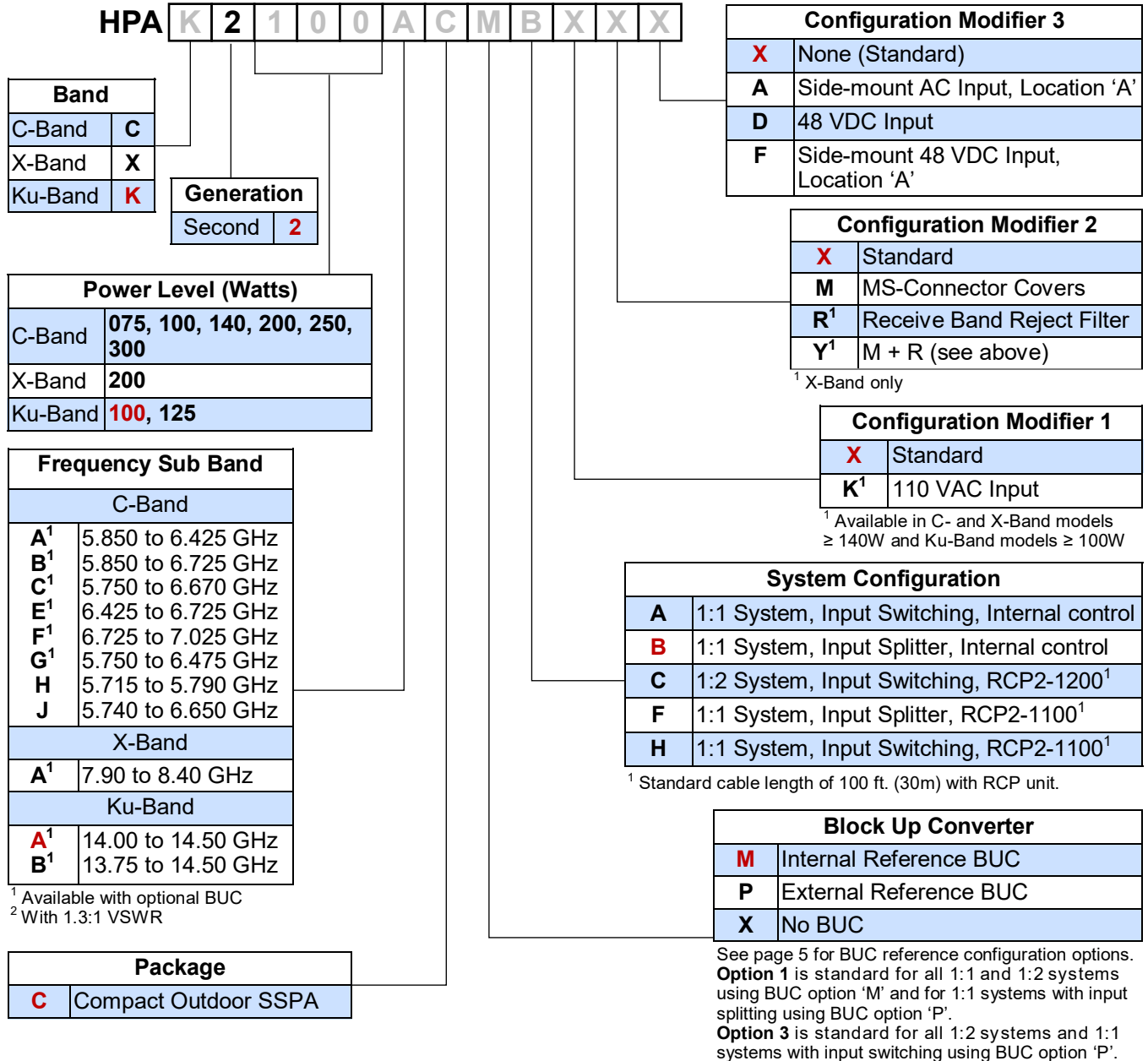

Example — A 70W GaAs Ku-Band (14.0 to 14.5 GHz) 1:1 Redundant Compact Outdoor SSPA System with input splitting, an internal reference block up converter, and internal redundancy control is model number: **HPAK2070ACMBXXX**.

COMMENTS:

Part Number Configuration Matrix, GaN Compact Outdoor Systems

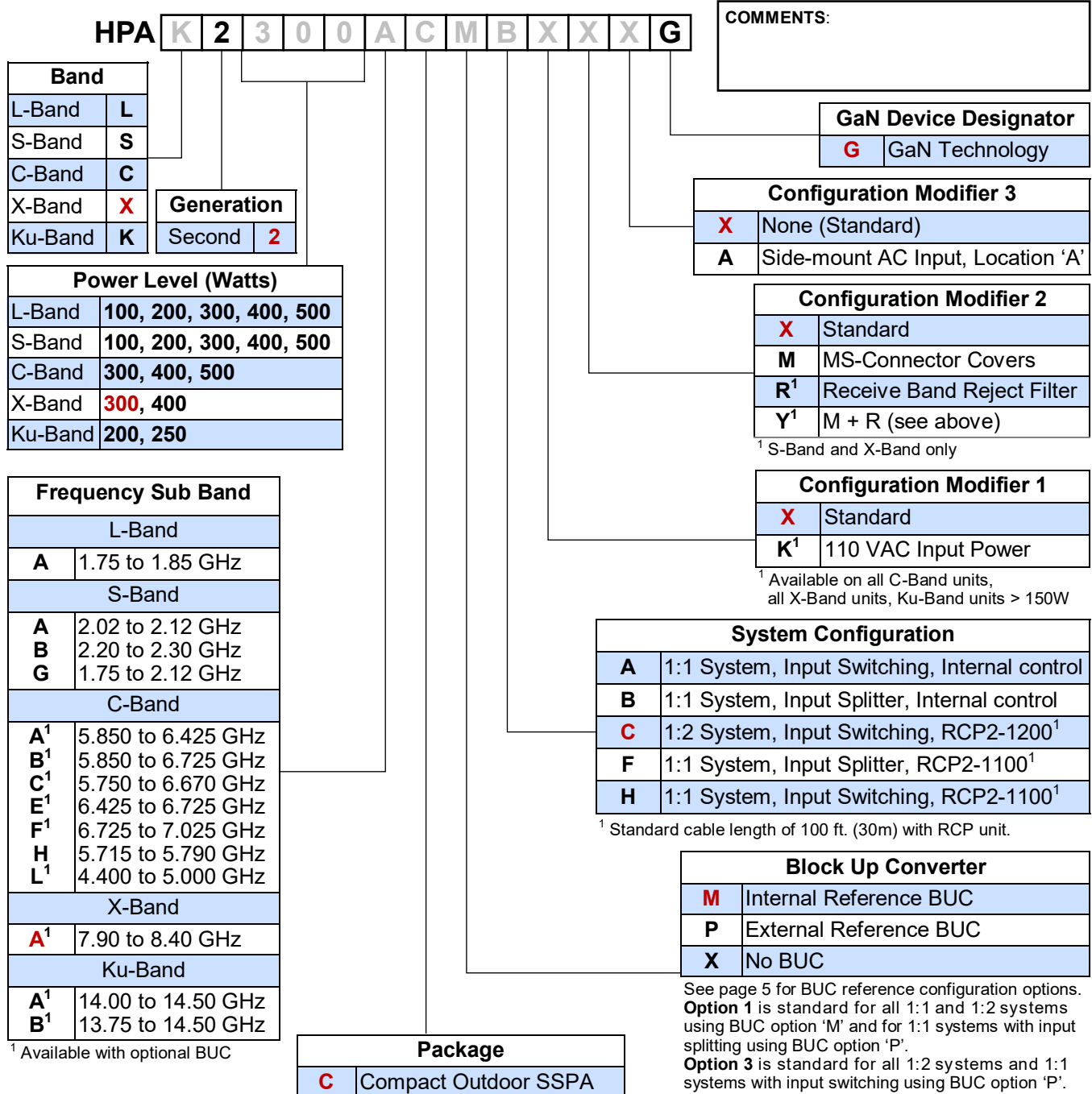

Use and Disclosure of Data: This product is classified as EAR99 and is subject to U.S. Department of Commerce regulations. Export, reexport or diversion contrary to U.S. law is prohibited.

Proprietary and Confidential: The information contained in this document is the sole property of Teledyne Paradise Datacom. Any reproduction in part or as a whole without the written permission of Teledyne Paradise Datacom is prohibited.

Specifications are subject to change without notice.